

GV93K, GV93L, GV113

VIBRATIONSSCHLEIFER ORBITAL SANDER

Druckluft-Vibrationsschleifer zum Schleifen planer Flächen in der Oberflächenbearbeitung.

Pneumatic random sander for grinding flat surfaces in surface treatment.



VORTEILE

- Leistungsstarkes Werkzeug mit hohem Abtrag und langer Standzeit für den industriellen Einsatz
- Ein ölfreier Betrieb ist möglich
- Ermüdungsfreies Arbeiten dank ergonomischer Bauform und niedriger Vibrationswerte ($< 2,5 \text{ m/s}^2$)
- Stufenlos regulierbare Drehzahl

BENEFITS

- Powerful tool with high removal rate and long service life for industrial use
- Oil-free operation possible
- Fatigue-free working thanks to ergonomic design and low vibration values ($< 2.5 \text{ m/s}^2$)
- Infinitely variable speed control



TECHNISCHE DATEN TECHNICAL DATA

Artikel	Item	GV93K	GV93L	GV113
Leistung	Power		375 Watt	
Drehzahl	Speed		8.000 min ⁻¹	
Hub	Stroke		Ø 5 mm	
Schleifplatte B x L x H	Grinding Plate W x L x H	93 x 170 x 9 mm (Typ 2071)	93 x 170 x 9 mm (Typ 2071)	113 x 215 x 9 mm (Typ 2072)
Ausführung	Model	kurz, Einhand-Bedienung short, one-hand operation	lang, Zweihand-Bedienung long, two-hand operation	lang, Zweihand-Bedienung long, two-hand operation
Gewicht	Weight	1,7 kg	1,8 kg	1,9 kg
Luftverbrauch	Air Consumption		11,0 l/s	
Luftanschluss	Air Connection		G1/4"	
Empfohlener Schlauch-Ø	Recommended Hose Ø		9 mm	
Betriebsdruck	Working Pressure		6,3 bar	
Artikel Nr.	Item No.	16156000	16157000	16166000

Lieferumfang:

Werkzeug mit Standard-Schleifplatte gelocht, Schlauchtülle, Schnellkupplungsstück

Scope of Delivery:

Tool with standard grinding plate perforated, hose nipple, quick-coupling nipple

ABMESSUNGEN DIMENSIONS

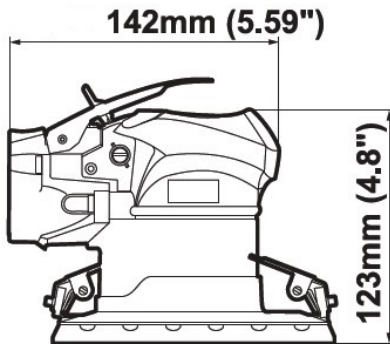

GV93K

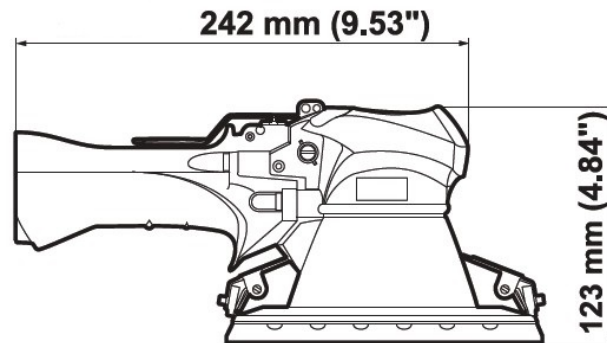

GV93L, GV113

ZUBEHÖR ACCESSORIES

Schleifplatten / Grinding Plates

Für Werkzeug For Tool	Typ Type	Beschreibung Description	Abmessungen Dimensions	Artikel-Nr. Item No.
GV 93...	 2071	Schleifplatte, Polyurethan, gelocht Grinding plate, poliurethane, perforated	93 x 170 x 9 mm	01433102
	 8990	Schleifplatte, Zellkautschuk Grinding plate, cellular rubber	93 x 172 x 12 mm	16199017
	 8990-K	Schleifplatte für Kletthaftung, Zellkautschuk Grinding plate velcro, cellular rubber	93 x 172 x 12 mm	16199019
GV 113...	 2072	Schleifplatte, Polyurethan, gelocht Grinding plate, poliurethane, perforated	113 x 215 x 9 mm	01433103
	 5936	Schleifplatte, Zellkautschuk Grinding plate, cellular rubber	114 x 216 x 12 mm	16199023
	 5936-K	Schleifplatte für Kletthaftung, Zellkautschuk Grinding plate velcro, cellular rubber	114 x 216 x 12 mm	16199025

Schleifpapier* / Abrasive Paper*

Für Werkzeug For Tool	Typ Type	Beschreibung Description	Korn Grain	Artikel-Nr. Item No.
Bogen, für GV Sheet, for GV	SFP-B-Korund	Korund Aluminium oxide 230 x 280 mm	80	16199558
			500	16199599
			40	16199504
Bogen, Klett für GV Sheet, vlcro, for GV	SFP-BK-Korund	Korund Aluminium oxide 230 x 280 mm	60	16199506
			80	16199508
			120	16199512
			150	16199515
			180	16199518



* Mindestabnahmemenge 1000 Stück / Minimum order quantity 1000 pieces